



Catch Basin Products

Conversion Riser For Type I-L Catch Basin

Reinforcing

- Reinforcing meets ASTM and WSDOT Standard Specifications
- All components #4 grade 60 reinforcing
- Opening surrounded by #4 bar typical

Modified Type 1L Catch Basin Reducing Section

- 500 lbs

Conformity Standards

- Washington State APWA / WSDOT Standard Specifications
- WSDOT B-1b

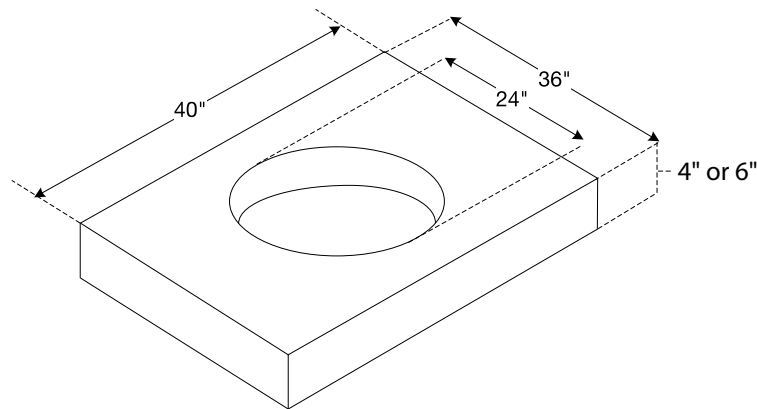

Note: Drawings not to scale

www.shopeconcrete.com

1-800-422-7560 [TOLL FREE]



Shope Concrete, LLC
1618 East Main Avenue
Puyallup, WA 98372-3142

(253) 848-1551
Fax Line 1 (253) 845-0292
Fax Line 2 (253) 864-6172

